

3.1.3 SSP SETUP OPTION USB 03

This setup option shows how to connect a SMART Hopper with an attached coin mech into a host machine via a USB COM Port by using available ITL cables and interfaces.

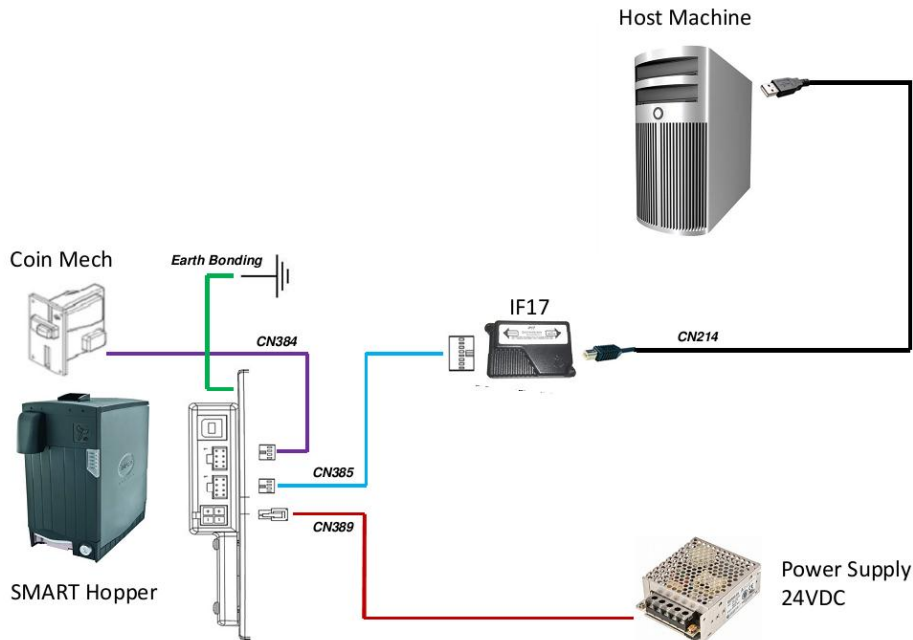

Drawing 3 – SSP SETUP OPTION USB 03

Part Name	Description	Quantity
SMART Hopper	Multi Denomination Coin Payout	1
IF17	USB Interface Converter	1
CN385	SMART Hopper User Interface Cable Assembly	1
CN384	Hopper to Coin Mech Cable Assembly	1
CN389	Hopper Interface Power Cable	1
CN214	USB A to B Cable Assembly	1

Table 3 – Content Table ITL products SSP SETUP OPTION USB 03

Power Requirements

This setup option requires a stable 24VDC / 6,5A power supply for only the SMART Hopper according to the product specification. Please refer to the SMART Hopper Manual Set GAxxx for full details of SMART Hopper's power requirements. Please check the power requirements of your host machine and other peripherals to dimension a proper power environment for your system setup.

Cautions

It is very important that the base plate of the SMART Hopper is bonded to earth, as lack of proper bonding can cause communication issues and failures. The earth bond on a SMART Hopper should be made to the intended connection on the base plate right next to the USB connector and be bonded to mains earth, typically through the Power Supply Unit. The resistance between the base plate and the Earth pin on the mains plug should be less than 0.7 ohms.